

AMF 120

Single Stage Fixed Louvre

**AUSTRAL
MONSOON**
ASSA ABLOY

The Future of Ventilation

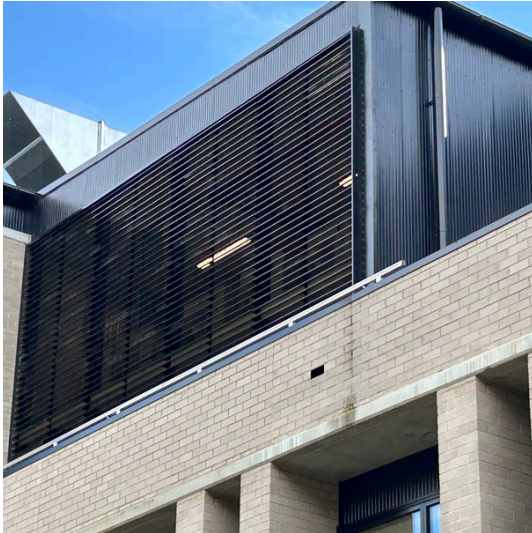

Austral Monsoon AMF 120 Louvre features a **4-fold blade design** with a 120 mm pitch, engineered to deliver **high airflow and reliable performance in low weather-exposed environments**. Its robust metal construction ensures durability and design flexibility, making it ideal for commercial and industrial applications.



Characteristics

- 4-fold Blade Single Stage fixed louvre system
- Material: Aluminium/ Steel/ Colorbond Steel/ Zincanneal Steel/ Stainless steel
- Frame Depth: 100mm
- Blade Pitch: 120mm
- Free Open Area: 50%
- Internal mesh options: Mesh material options:
 - Bird Mesh
 - Insect Mesh
 - Vermin Mesh
 - Security Screens
 - Fibreglass
 - Galvanised Steel
 - Stainless Steel
- Available in integrated louvred doors

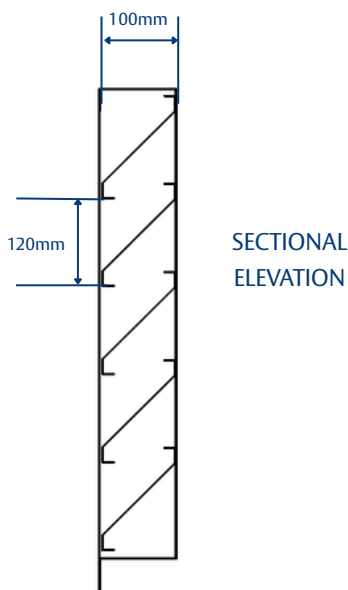

Applications

- Ideal for commercial and industrial projects requiring high airflow and low weather exposure, including:
 - Air inlet and exhaust ventilation panels
 - Plant rooms and equipment enclosures
 - Utility and service areas requiring durable airflow



Finishing Options

- Depending on base sheet metal, generally supplied in
- Powder Coated
 - Natural Anodised
- Other special finishes available upon request



Performance

- Engineer Certified AS/NZS 1170; AS/NZS 1664; AS 4055; AS4100; AS 2047

Want to know more?

Ask us for a [AMF 120 Datasheet](#) or ask our design team for advice.



www.ambps.com.au

(07) 3271 2877

Scan for more information



AUSTRALIAN
**GLASS &
WINDOW**
ASSOCIATION
MEMBER